

2. Installation

Receiving/Inspection

- Unpack carefully
- Verify that all items in the packing list are received and are correct.
- Inspect all instruments for damage or contaminants prior to installation.

If the above three items are satisfactory, proceed with the installation. If not, then stop and contact a customer service representative.

Packing/Shipping/Returns

These issues are addressed in Appendix C - Customer Service

Factory Calibration Note

The flowmeter is factory calibrated to the flow range specified in the order. There is no need to perform any verification or calibration steps prior to installing and placing the flowmeter in service.

Pre-Installation Procedure



Warning: Only qualified personnel should install this instrument. Install and follow safety procedures in accordance with the current National Electrical Code. Ensure that power is off during installation. Any instances where power is applied to the instrument will be noted in this manual. Where the instructions call for the use of electrical current, the operator assumes all responsibility for conformance to safety standards and practices.



Caution: The flowmeter is not designed for weld-in-place applications. Never weld to process connection or a structural support.

Damage resulting from moisture penetration of the flow transmitter or flow element enclosure is not covered by product warranty.

The flow transmitter contains ESD components. Use standard ESD precautions when handling the flow transmitter. See below for ESD details.

Use Standard ESD Precautions

Use standard ESD precautions when opening an instrument enclosure or handling the flow transmitter. FCI recommends the use of the following precautions: Use a wrist band or heel strap with a 1 megohm resistor connected to ground. If the instrument is in a shop setting there should be static conductive mats on the work table and floor with a 1 megohm resistor connected to ground. Connect the instrument to ground. Apply anti static agents to hand tools to be used on the instrument. Keep high static producing items away from the instrument such as non-ESD approved plastic, tape and packing foam.

The above precautions are minimum requirements to be used. The complete use of ESD precautions can be found in the U.S. Department of Defense Handbook 263.

Verify Serial Numbers

Verify that the flow elements' serial number matches the flow transmitter serial number. A tag indicating the serial number is located on the local and remote enclosures, see Figures A-2, A-3, and A-4.

When multiple flow elements connect to one flow transmitter, each flow element serial number has a suffix that represents the flow element number. For example, if two flow elements connected to a flow transmitter have a base serial number of 123, then the first flow element would have the serial number 123-1, and the second flow element would have the serial number 123-2.

Prepare or Verify Flow Element Location

Mount the flow element at least 20 diameters downstream and 10 diameters upstream from any bends or interference in the process pipe or duct to achieve the greatest accuracy.

Mount the flow element where the flow stream temperature is well above the saturation temperature of any of the process gases. If a component of the process media is near its saturation temperature, it will probably condense on the sensing points. Liquid on the sensing points will drive the flow measurement higher than actual.

The flow element's shape is cylindrical with a diameter of 2 inches. The length is customer specified. The recommended diameter for the clearance hole needed to mount the flow element is 2.03 inches. See Figure A-5 for recommended process connection.

For optimum performance, prepare additional support at the end of the flow element for instruments exceeding 2 feet in length. Refer to Figure A-5, and A-6 for recommended end support configuration.

Verify Dimensions

Verify the flow element and flow transmitter dimensions as shown in Appendix A.

Verify Flow Direction for Flow Element Orientation and Placement

The flow element comes with a FLAT area machined on the flow element near the enclosure. Etched in the FLAT is a FLOW ARROW indicating the direction of flow. See Figure 2-1.

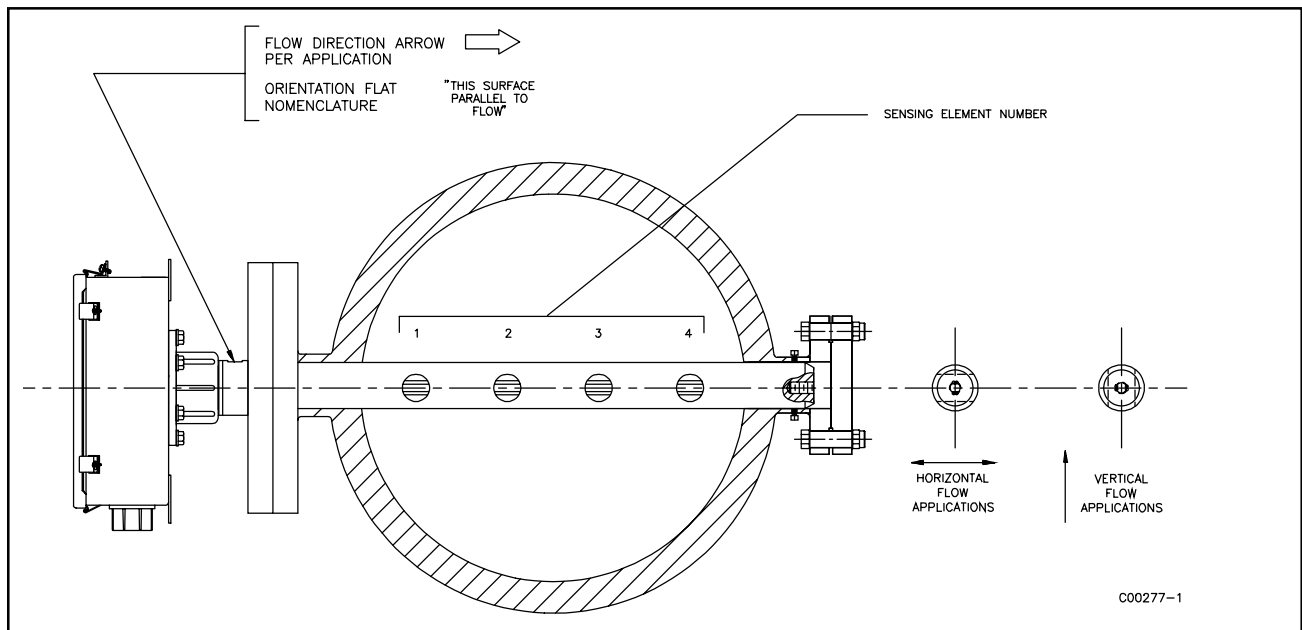

Figure 2-1. Flow Element Showing FLAT Area

Align the flow element during installation so the FLAT is parallel, to the direction of the process media flow, and the FLOW ARROW points in the direction of process media flow. Failing to install the flow element correctly will reduce the accuracy of the flowmeter.

Install Flow Element

Install the flow element as specified for the process connection type used. If applicable, connect the end of the flow element to one of the recommended mechanical supports. See Figure A-5 or A-6.

Threaded Mounting



Note: When mounting the flow element to the process duct, it is important that a lubricant/sealant is applied to the male threads of all NPT connections. Be sure to use a lubricant/sealant compatible with the process environment. Tighten all connections firmly. To avoid leaks do not overtighten or cross-thread connections.

1. Verify end hardware is loose if present. Carefully insert flow element into process mount. Align with end support if present.
2. Verify that the process media is in the same direction as the FLOW ARROW on the FLAT.
3. Threads are right-handed. Place pipe wrench on unthreaded portion of metal shaft. Rotate until snug and continue to turn until FLAT is horizontal to process flow. Apply even pressure so as not to disfigure nipple.



Caution: Do not apply any leverage to the local enclosure itself.

4. Tighten all connections firmly. Tighten all end hardware firmly if present.

Flanged Mounting

1. Verify end hardware is loose if present. Carefully insert flow element into process mount. Align with end support if present.
2. Attach the process mating flange with care. Maintain the correct orientation of the flow element to ensure accuracy.
3. Verify that the Process Media is in the same direction as the FLOW ARROW on the FLAT.
4. Apply the appropriate gasket and/or sealant to flange mount faces as required.
5. Attach with a bolt, two flat washers, lock washer and nut for each bolt hole; apply lubricant/sealant to male threads and torque. Refer to ANSI B16.5 specifications.
6. Tighten all connections firmly.

Install Flow Transmitter

Use Figures 2-2 and 2-3 throughout this section.



Caution: Pulling wires can cause damage to the electronic components. Use extreme care when pulling wires into the remote enclosure.

In applications where the flow element is located in an explosive environment, isolate the conduit before it leaves the environment. A potting Y may be used to provide the isolation.

Minimum Wire Size

Table 2-1 shows the smallest (maximum AWG number) copper wire that should be used in the electrical cables. Use a lower gauge of wire for less of a voltage drop. Contact FCI concerning greater distances than those listed in the chart.

Table 2-1. Interconnecting Cable Size (AWG)

Connection	Maximum Distance for AWG					
	10 ft. (3m)	50 ft. (15m)	100 ft. (31m)	250 ft. (76m)	500 ft. (152m)	1000 ft. (305m)
AC Power	22	22	22	20	18	16
Relay (2A)	28	22	20	16	12	10
Flow Element Wires*	24	24	24	22	22	18
*Requires a shielded cable which is connected to the Flow Transmitter						

Remote Hardware

Figures A-3 and A-4 show the remote enclosures along with physical dimensions to properly mount the flow transmitter. Select a location for the flow transmitter within 1000 feet of the flow element. This location should be easily accessible with enough room to open the enclosure cabinet door or remove a panel at any time. Secure the flow transmitter solidly to a vertical surface capable of providing support. Use nuts and bolts to secure the flow transmitter.

Power Connection Information



Note: The installation of an AC line switch between the AC power source and the flowmeter is recommended. This facilitates easy power disconnection and is an added safety feature.

The flow element power supply is not field selectable. Connect 85-265 Vac operating power and a power ground to the flow transmitter. Follow the appropriate procedure below to connect power.

NEMA 4 Remote Enclosure

Install the customer supplied conduit and/or cable through the 1 inch female NPT ports. Remove the terminal block shield located at the top right hand corner on TB1 and wire according to Figure 2-2.

Rackmount Remote Enclosure

Install the customer supplied conduit or cable through the back side of the enclosure. Remove the terminal block shield located on the left wall (looking from the rear) on TB1 and wire according to Figure 2-2.

Sensing Point Connections

There are up to 16 different sensing points per flow transmitter. Sensing point 1, on the flow element, is the point closest to the local enclosure. Sensing point 2 is the next down, etc.

In the local enclosure, sensing points are identified on the terminal board. For example, TB1-HD1 connects to sensing point 1. In the remote enclosure, sensing points are identified by the connector number. For example, J1 corresponds to sensing point 1.

1. Run eight-conductor-shielded cable from the local enclosure to the remote enclosure for each sensing point. Use Table 2-1 to determine which wire gauge to use.
2. In the local enclosure is an 8-pin connector for each sensing point, wire each cable to a connector per Figure 2-2.



Note: Before inserting the cable wires into the terminal strip connector, turn the screw counterclockwise 7 turns. If this is not done, it is possible to insert the wire between the top half of the clamp and the frame instead of between the two clamp segments.

3. Tag the cables to clarify which cable connects to which sensing point. Follow the appropriate procedure below to connect sensing points.

NEMA 4 Remote Enclosure

1. In the remote enclosure is a 10-pin connector for each sensing point. Open the enclosure door and remove connectors. Wire each cable to a connector per Figure 2-2.



Note: Do not wire to HBS and HBX.

2. Plug the connectors back into the appropriate sockets, matching sensing point number to each socket number. For example, connect sensing point #1 to socket J1. See Figure A-2.
3. After connecting all sensing points, secure door of enclosure.

Rackmount Remote Enclosure



Warning: High voltage is present on the inside of the right panel. Ensure that power is off before proceeding.

1. Remove the left panel to access connectors J1 through J6. Pull the panel away from the instrument and remove the ribbon cable from the display card connector (J18).
2. Remove the right panel to access connectors J7 through J16.
3. In the remote enclosure is a 10-pin connector for each sensing point. Remove connectors and wire each cable to a connector per Figure 2-2.

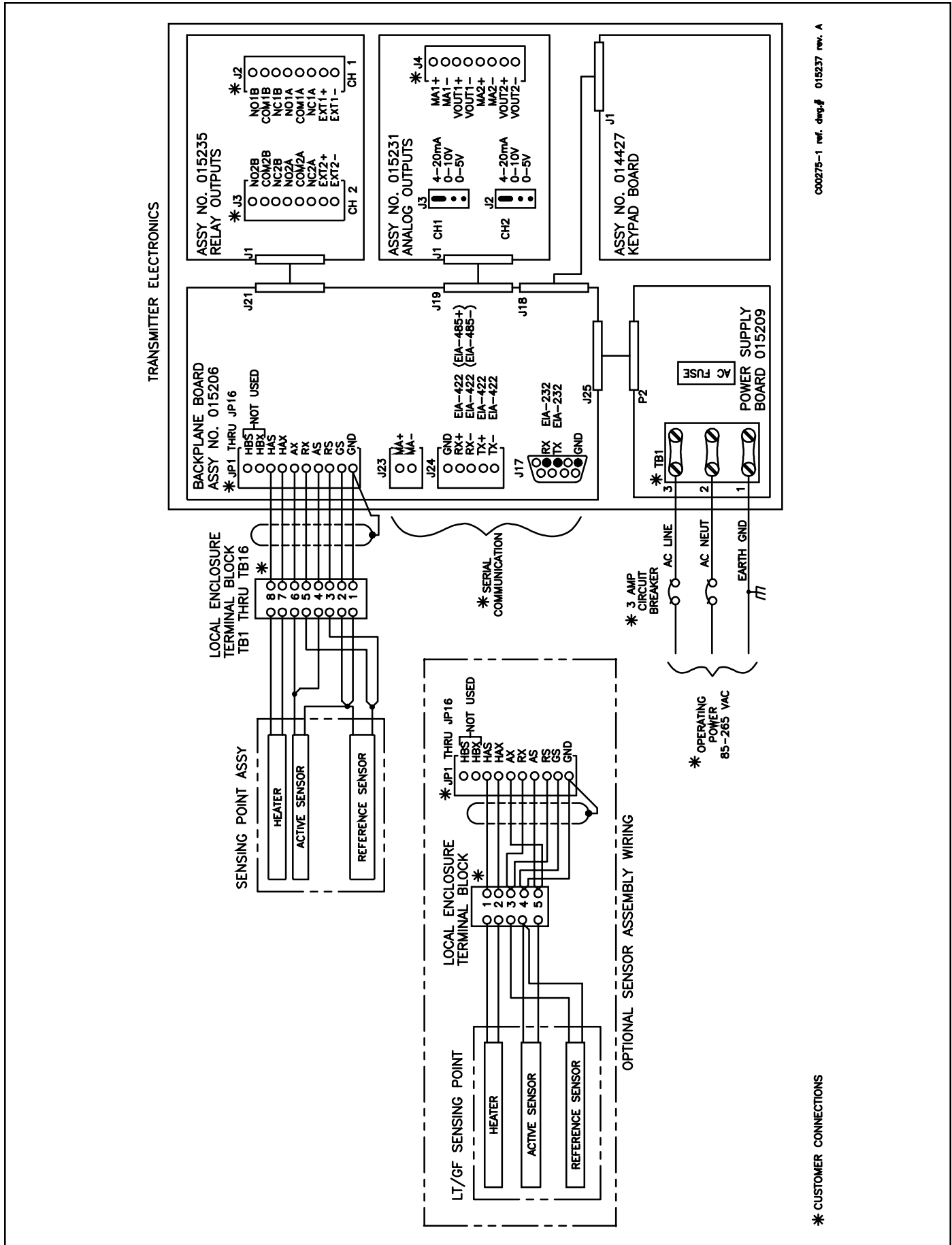

C00275-1 rev. chg.# 015237 rev. A

* CUSTOMER CONNECTIONS

Figure 2-2. MT91 Wiring Diagram

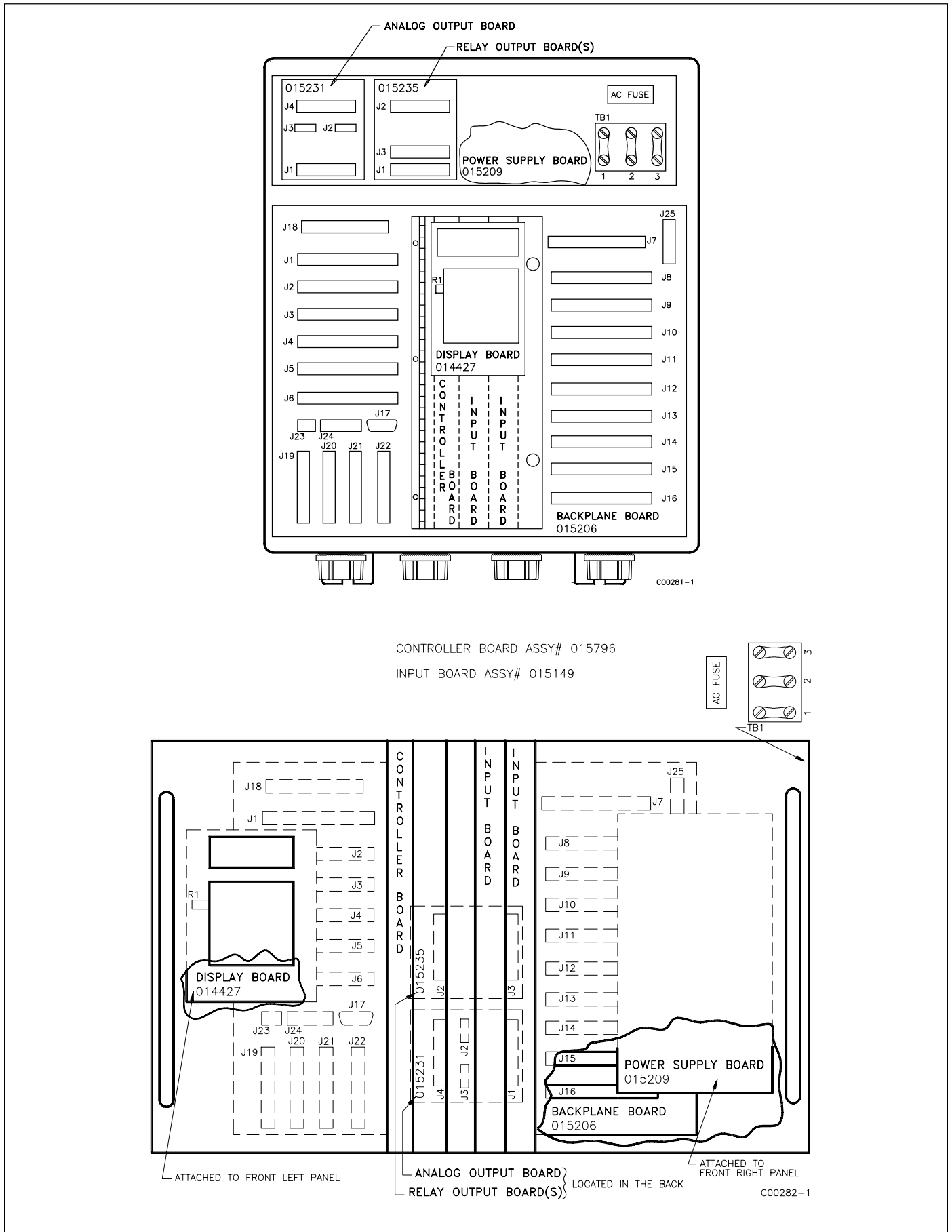

Figure 2-3. Flow Transmitter Outline for NEMA 4 and Rackmount Remote Enclosures



Note: Do not wire to HBS and HBX terminals.

3. Plug back in the connectors to the appropriate sockets, matching sensing point number to each socket number. For example, connect sensing point 1 to socket J1. See Figure 2-3.
4. After connecting all sensing points, plug the display ribbon cable back into J18 and secure panels of enclosure.

Customer Connections

Analog Output Board - Assy #015231 (see Figure 2-3 for location)



Note: If a different jumper position is selected other than the factory calibrated position, a complete re-calibration of the analog output board will be necessary. See Chapter 3 for how to calibrate the analog output board.

Jumper J2

This jumper provides three output options for channel 1. Select one and place the jumper in the corresponding position. See Figure 2-2 for jumper location.

- 4 to 20 milliamperes
- 0 to 10 volts
- 0 to 5 volts

Jumper J3

This jumper provides three output options for channel 2. Select one and place the jumper in the corresponding position. See Figure 2-2 for jumper location.

- 4 to 20 milliamperes
- 0 to 10 volts
- 0 to 5 volts

Connector J4

This connector interfaces with customer instrumentation. Refer to Table 2-2 for signal information.

Table 2-2. Connector J4 Signal Information

Signal (Power Isolated)	Description	
Vout2-	Channel 2 voltage output return.	Connected to system signal ground.
Vout2+	Channel 2 voltage output signal.	0 to 5 Vdc or 0 to 10 Vdc
MA2-	Channel 2 current output return.	Connected to system signal ground
MA2+	Channel 2 current output signal.	0 to 22 mAdc
Vout1-	Channel 1 voltage output return.	Connected to system signal ground.
Vout1+	Channel 1 voltage output signal.	0 to 5 Vdc or 0 to 10 Vdc
MA1-	Channel 1 current output return.	Connected to system signal ground.
MA1+	Channel 1 current output signal.	0 to 22 mAdc

Relay Output Board - Assy #015235 (see Figure 2-3 for location)

One relay output board supports up to 2 relays. Relays 3 and 4 are not associated with Analog Output Channels and are optional.

Connector J1

This connector interfaces with the flow transmitter backplane board.

Relays 1 and/or 2 Relay Board J1 connects to Backplane Board J21
Relays 3 and/or 4 Relay Board J1 connects to Backplane Board J22

Connector J2

This connector provides the relay outputs for relay 1 or 3, depending on which backplane connector J1 is associated. Refer to Table 2-3 for signal information.

Connector J3

This connector provides the relay outputs for relay 2 or 4, depending on which backplane connector J1 is associated. Refer to Table 2-3 for signal information.

Table 2-3. Connector J2 and J3 Signal Information

Signal (Power Isolated)	Description	
EXT1-	Relay 1 external signal drive signal.	Open collector of NPN transistor. +30 Vdc Max.
EXT1+	Fused connection to +24 Vdc	Fuse rating is 1/16 A (62.5 mA)
NC1A	Relay 1A Normally Closed terminal.	Continuity with COM1A when relay is de-energized
COM1A	Relay 1A Common terminal.	
NO1A	Relay 1A Normally Open terminal.	Continuity with COM1A when relay is energized.
NC1B	Relay 1B Normally Closed terminal.	Continuity with COM1B when relay is de-energized.
COM1B	Relay 1B Common terminal.	
NO1B	Relay 1B Normally Open terminal.	Continuity with COM1B when relay is energized.
EXT2-	Relay 2 external signal drive signal.	Open collector of NPN transistor. +30 Vdc Max.
EXT2+	Fused connection to +24 Vdc.	Fuse rating is 1/16 A (62.5 mA)
NC2A	Relay 2A Normally Closed terminal.	Continuity with COM2A when relay is de-energized
COM2A	Relay 2A Common terminal.	
NO2A	Relay 2A Normally Open terminal.	Continuity with COM2A when relay is energized.
NC2B	Relay 2B Normally Closed terminal.	Continuity with COM2B when relay is de-energized.
COM2B	Relay 2B Common terminal.	
NO2B	Relay 2B Normally Open terminal.	Continuity with COM2B when relay is energized.

Serial Communication Ports - Backplane Board Assy # 015206 (see Figure 2-3 for location)

Connector J17 - EIA-232

This connector provides serial communications for compatible equipment. Refer to Figure 2-4 for wiring configuration.

Connector J23 - 4-20 mA

This connector provides analog communication for compatible equipment. Refer to Figure 2-2 for wiring information.

Connector J24 - EIA-422/EIA-485

This connector provides serial communication for compatible equipment for a EIA-422 port or EIA-485 port. To use the EIA-422 connection, wire according to Figure 2-2 and 2-5. To use the EIA-485 connection, wire only the GND, RX+, and RX- according to Figure 2-2 and 2-5. Multiple instruments can interface with the host system with the EIA-485 connectors.

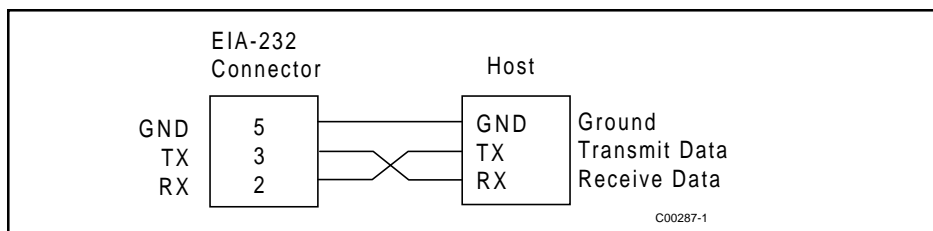

Figure 2-4. Wiring Diagram for Serial Connector EIA-232

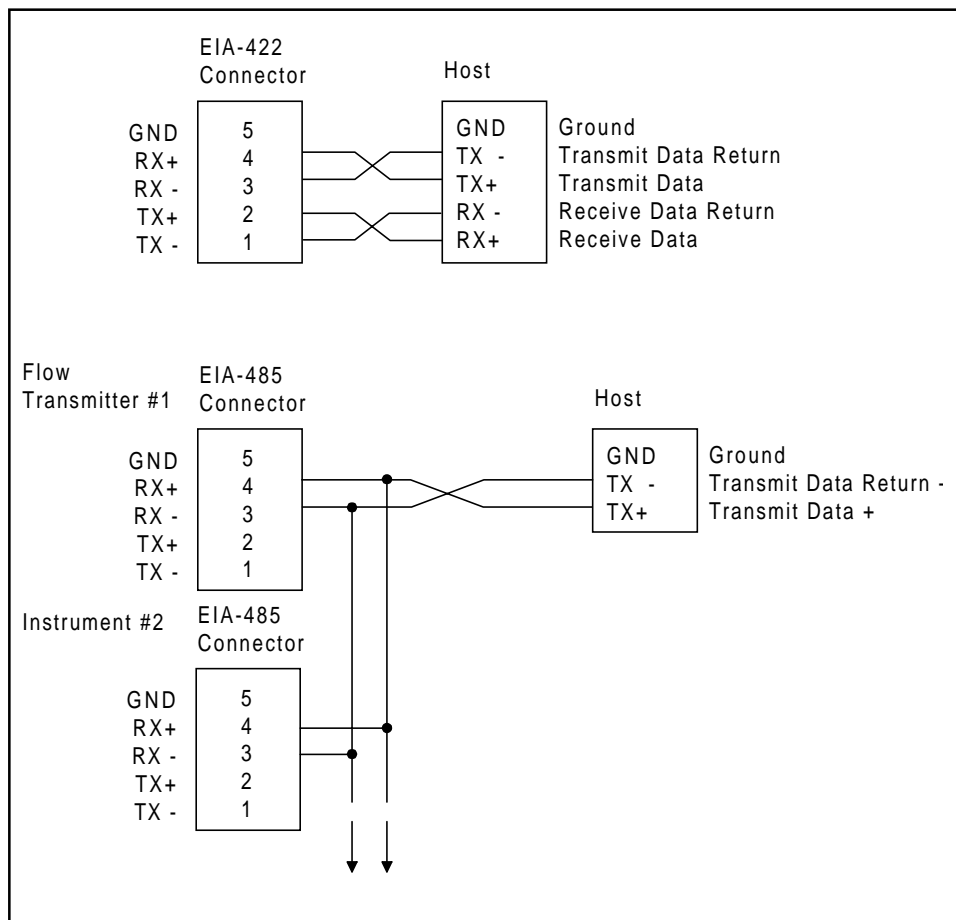

Figure 2-5. Wiring Diagram for Serial Connectors EIA-422 & EIA-485

Installation Quick-Check List

1. Verify that serial numbers match.
2. Be sure the FLAT and FLOW ARROW are properly oriented.
3. Ensure there are no leaks at the process connection.
4. Verify that the wiring is properly connected per the appropriate diagram.

Proceed to Chapter 3 - Operation to begin power-up sequence.

