

NuTec Series Flow & Level Detection Instruments Installation and Operation Guide

Quick Installation and Adjustment Overview

Section A - Instrument Description and Identification

Verify if ordered configuration was received, and if what was received fits the application.

Section B - Instrument Installation

Install the instrument on to the application in the orientation required. Take extra precaution not to damage the sensing elements/surface. If wiring conduit is required, make sure there are no obstructions leading to the wiring ports. Check for leaks.

Section C - Instrument Wiring

Verify the power and output load requirements for the instrument and install the proper wire size for the application. Wiring to relays will require knowledge of the alarm state and load circuit. Take extra precaution not to damage the control circuits.

Section D - Power Up, Functional Verification and Adjustment.

Before applying power to the instrument, inspect the installation workmanship. In most cases the instrument will detect a flow or level alarm with the factory settings. If the instrument does not respond, responds slowly or the alarm responds opposite to the required indication, follow the adjustment procedure in this section or go to Section E.

Section E - Maintenance and Troubleshooting

Section A - Instrument Description and Identification

Thoroughly understanding the capabilities of the NuTec instrument, and its intended use for your application, will make the installation much easier. This installation guide describes three NuTec models. FCI suggests that you copy the part number suffix code on the instrument tag to the specification page (next page). Highlight the code descriptions as well as all the sections in this guide that pertain to the model you purchased. Special customer options or variations will have a "W" or an "asterisk" in the affected code space. If there is a model discrepancy, call customer service before installing.

LS2000

The model LS2000 is an insertion instrument capable of detecting liquid levels or product interfaces in a wide range of processes. The instrument can be top or side mounted. The process connection choices are male ¼ inch NPT, ¾ inch NPT or 1-1/2 inch, 150 lb. Flange. See the installation outline drawings on page 3 or 4 for the correct mounting dimensions.

FS2000

The model FS2000 is an insertion instrument capable of detecting flow / no-flow in a wide range of processes. The instrument can be top or side mounted. The process connection choices are male ¼ inch NPT, ¾ inch NPT or 1-1/2 inch, 150 lb. flange. See the installation outline drawings on page 3 or 4 for the correct mounting dimensions.

FS2000L

The model FS2000L is a non-intrusive, in-line instrument capable of monitoring the flow rate of a wide range of gas or liquid processes. The instrument can be mounted vertically or horizontally. The process connection choices are male NPT, butt weld or sanitary flange. See the installation outline drawings on page 3 or 4 for the correct mounting dimensions.

Use Code One
 FS2000 – [] [] [] [] [] [] (Flow)
 1 2 3 4 5 6

Use Code One
 LS2000 – [] [] [] [] [] [] (Level)
 1 2 3 4 5 6

Use Code Two
 FS2000L – [] [] [] [] [] [] (In Line Flow, Non-Intrusive)
 1 2 3 4 5 6

1. Materials of Construction	Code One	Code Two	2. Process Connection	Code One	Code Two	3. LS / FS2000 Insertion length	Code One	Code Two	4. Local Enclosure	Code One	Code Two	5. Input Power	Code One	Code Two	6. Process Media ⁵	Code One	Code Two
316L stainless steel for all wetted surfaces	A	A	316L Only ¾ inch Male NPT	1	See Next	3. FS2000L In-Line Tube I.D. Size⁹ →			Aluminum, NEMA Type 4X, Hazardous Locations Groups C and D (4 –20 mA Loop Power Only)	2	NA	4 –20 mA Loop Power ³	A	NA	Liquid Gas	1 2	1 2
304 / 305 stainless steel ¹	B	NA	1½ inch, 150 lb. Carbon Steel Raised Face Flange ²	2	NA	316L Only 1.2 inch [31mm]	C	NA	Aluminum, NEMA Type 4X, Hazardous Locations Groups B, C, D, E, F & G [IP66], One conduit port.	3	3	100-240 Vac ^{1,7}	B	A	Liquid with Temperature Compensation, Temp Swing >+/- 30°F [+/-16.7°C] ⁶	3	NA
Sanitary 3A (20 Ra) High Purity ⁸	NA	B	1½ inch, 150 lb. Stainless Steel Raised Face Flange ²	3	NA	2.0 inch [51mm]	A	NA				24 Vdc / Vac	C	B	Agency Approved Customer Specified	W	W
Sanitary 3A (10 Ra) Ultra High Purity ⁸	NA	C	304 / 305 Only ¾ inch Male NPT	4	NA	304 / 305 Only 0.98 inch [25 mm]	D	NA	Same as option "3" but with two conduit ports and mounting holes.	4	4	Other	*	*	Liquid with Temperature Compensation, Temp Swing >+/- 10°F [+/-16.7°C] ⁶	NA	3
Agency Approved Customer Specified	W	W	Butt Weld ¹³	NA	1	3.80 inch [97 mm]	F	NA	Weather Proof	NA	1				Gas with Temperature Compensation, Temp Swing >+/- 10°F [+/-16.7°C] ⁶	NA	4
			Sanitary Flange ^{10,12}	NA	2	1/2 inch [12 mm]	NA	A	Weather Proof with window for LED alarm indicator	NA	2				Agency Approved Customer Specified	W	W
			Male NPT ¹²	NA	3	1 inch [25 mm]	NA	B	Agency Approved Customer Specified	W	W				Other	*	*
			Agency Approved Customer Specified	W	W	2 inch [51 mm]	NA	C									

SPECIFICATIONS

Model: FS2000 Insertion Flow Switch (I) LS2000 Insertion Level Switch (II) FS2000L In-Line Flow Switch, Non-Intrusive (III)	LS2000 Level Switch Accuracy: Top Mount: +/-0.250 inch [+/-6 mm] from element tip. Side Mount: +/-0.125 inch [+/-3 mm] from centerline of element tip. Response Time: Dry to Wet: Less than 2 seconds Wet to Dry: Less than 5 seconds Wet to Wet (interface): Less than 10 seconds												
Material of Construction: 304 / 305 Stainless Steel ¹ or 316L Stainless (I & II), 316L Stainless Steel (III)	FS2000 Flow Switch Setpoint Range: Water: 0.1 - 1.5 fps [0.03 - 0.45 mps] Hydrocarbon: 0.1 - 2.0 fps [0.03 - 0.60 mps] Air/Gas: 0.5 - 100 sfps [0.15 - 30 nmps] Repeatability: +/- 1% of "Setpoint Range" Response Time: 0.5 - 2.5 seconds												
Operating Temperature: Sensor Element: -40° to 250° F [-40° to 121° C] Control Circuit: 0° to 140° F [-18° to 60° C]	FS2000L Flow Switch (Non-Intrusive) Setpoint Range: Water: 0.1 - 10 fps [0.03 - 3.1 mps] Air/Gas: 0.5 - 300 sfps [0.15 - 91.4 nmps]												
Maximum Operating Pressure: For Process Connections With: Male NPT: 500 psig [35 bar (g)] Butt Weld: 500 psig [35 bar (g)] Flanges ¹⁰ : 100 psig [7 bar (g)]	<table border="1"> <thead> <tr> <th>Tubing</th> <th>Air / Gas</th> <th>Water¹¹</th> </tr> </thead> <tbody> <tr> <td>½ inch</td> <td>1.02 - 13.4 scfm [0.000 - 0.38 scmm]</td> <td>0.03 - 3.4 gpm [0.11 - 12.9 lpm]</td> </tr> <tr> <td>1 inch</td> <td>0.12 - 74 scfm [0.0030 - 2.10 scmm]</td> <td>0.18 - 18.5 gpm [0.68 - 70 lpm]</td> </tr> <tr> <td>2 inch</td> <td>0.57 - 342 scfm [0.0160 - 9.70 scmm]</td> <td>0.85 - 85.5 gpm [3.22 - 324 lpm]</td> </tr> </tbody> </table>	Tubing	Air / Gas	Water ¹¹	½ inch	1.02 - 13.4 scfm [0.000 - 0.38 scmm]	0.03 - 3.4 gpm [0.11 - 12.9 lpm]	1 inch	0.12 - 74 scfm [0.0030 - 2.10 scmm]	0.18 - 18.5 gpm [0.68 - 70 lpm]	2 inch	0.57 - 342 scfm [0.0160 - 9.70 scmm]	0.85 - 85.5 gpm [3.22 - 324 lpm]
Tubing	Air / Gas	Water ¹¹											
½ inch	1.02 - 13.4 scfm [0.000 - 0.38 scmm]	0.03 - 3.4 gpm [0.11 - 12.9 lpm]											
1 inch	0.12 - 74 scfm [0.0030 - 2.10 scmm]	0.18 - 18.5 gpm [0.68 - 70 lpm]											
2 inch	0.57 - 342 scfm [0.0160 - 9.70 scmm]	0.85 - 85.5 gpm [3.22 - 324 lpm]											
Input Power: 100 - 240Vac, 5 watts max. 22.5 - 26Vdc / 21.5 - 26.5Vac; 3 watts max. Two Wire (Loop Power), (I & II only) 4-20mA, 18-29.5Vdc at Control Circuit	Repeatability: +/- 1% of Alarm Setpoint Accuracy: +/- 3% of Alarm Setpoint + 0.25% of "Setpoint Range" Response Time: Adjustable from 0.5 - 2.5 seconds												
Signal Output: Relay ¹⁴ : SPDT 6 amp Max @ 240Vac Resistive; 20mA or 10Vdc Min, Resistive NPN Open Collector, (on all) 0 - 250mA, Open @ Alarm 4-20mA loop Power Alarm (Two Wire) (I & II only) ³ 14mA to 18mA transition for Alarm or 18mA to 14mA transition for Alarm													
Installation: Top or side mount. Axial flow direction permissible. ⁴													
Service: General Purpose for Gases and Liquids													
Agency Approvals: FM, CSA, CE Mark and ATEX ¹ Sanitary 3A, ASME BPE													

NOTES

- Approvals Pending
- All flanges are raised faced phonographic serrated
- Customer must provide a 4 - 20 mA current loop that will maintain 18 to 29.5 volts at the controller control circuit.
- Elements tips not required to be at centerline. Element tips must be extended into the flow stream for optimum performance.
- Contact FCI for custom insertion lengths.
- Applications with temperature changes greater than +/- 30° F for FS2000 / LS2000 and +/- 10° F for FS2000L will impact accuracy. FCI suggests temperature compensation for these applications.
- Available with aluminum local enclosure (Code 3 in box 4). Approvals Pending.
- Electro polished wetted surface finish in micro inches.
- Process connection size is the same as tube size.
- Sanitary flange is rated at lower pressure.
- Values are higher for hydrocarbons and viscous liquids.
- Available only with Box 1 Code A; Standard.
- Process connection must be butt weld or sanitary flange on Sanitary 3A instruments.
- Not Available with the loop power option.

Section B - Instrument Installation

For the FS2000 and the LS2000, there is an orientation mark  etched onto the sensor element. It is located on a flattened area of the sensor element body close to the housing.

For the LS2000, the orientation mark must be perpendicular to the liquid level. The sensor element can also be installed top mount 90° to the liquid surface.

For the FS2000, the orientation mark must be parallel to flow, (+/- 2°). For vertical flows, FCI recommends that the sensor element be installed where the flow is going in the up direction.

For the FS2000L, there is a flow arrow mark  etched onto the sensor element. It is located on the sensor element body close to the housing. The sensor element can be at any angle as long as the flow direction follows the flow arrow. If the flow element is positioned other than horizontally, FCI recommends that the flow go in the up direction.

For all models, the position of the sensor element in reference to the media is paramount. With this in mind, the position of the control circuit enclosure also needs to be considered. After the sensor element is installed, the enclosure cover must be accessible for wiring and servicing. It is preferred that the conduit port is positioned in a downward direction to reduce the possibility of moisture collecting in the enclosure. The enclosure may be repositioned by up to 1/2 turn to facilitate conduit installation.

CAUTION: To minimize the possibility of damage, leave the protective covers over the sensing area until the time of installation. Take extra precaution with the sensing elements and surface when installing.

For NPT process connections, apply the appropriate sealant compatible with the process media to the male threads. Tighten until the orientation mark is positioned correctly. Check for leaks.

For flange connections, refer to the installation outline diagrams. The bolt pattern on the process connection flange must be positioned in a way that the orientation mark on the sensor element ends up in the correct position as mentioned above. Use gasket material compatible to the process media. Check for leaks.

For sanitary flange connections, use o-rings compatible with the media. Position the o-ring(s) and join the sanitary flanges. Install the flange clamp(s) snug to permit rotation of the sensor element. Rotate the sensor element until the orientation mark is correctly positioned. Tighten the clamps and check for leaks.

For butt weld connections, make sure all parts are cleaned. Mount the instrument to check fit. Make sure the flow arrow is in the same direction of flow. Align the inside diameter (I.D.) of the instrument to the I.D. of your piping. Tack weld in place. A qualified welder should perform welding per ASME Section IX, Boiler Code. For best results, 100% penetration with the weld size of 1 1/2 times the wall thickness is desired. Check for leaks.

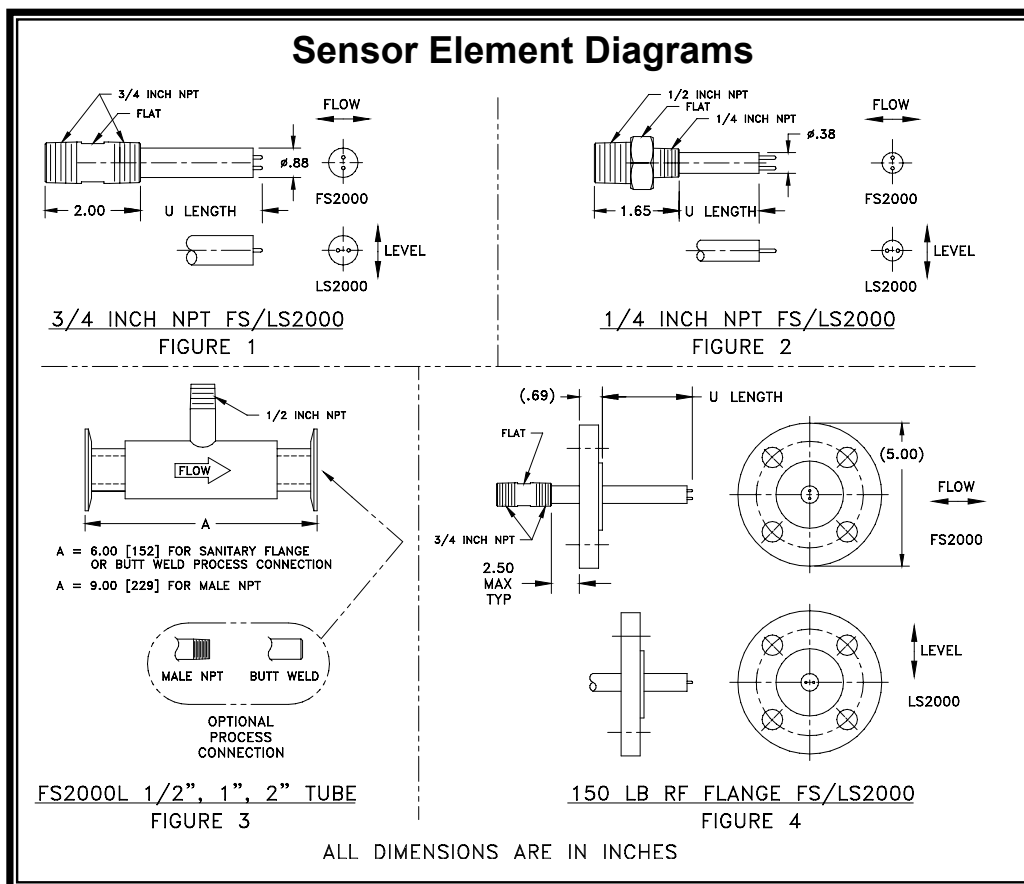

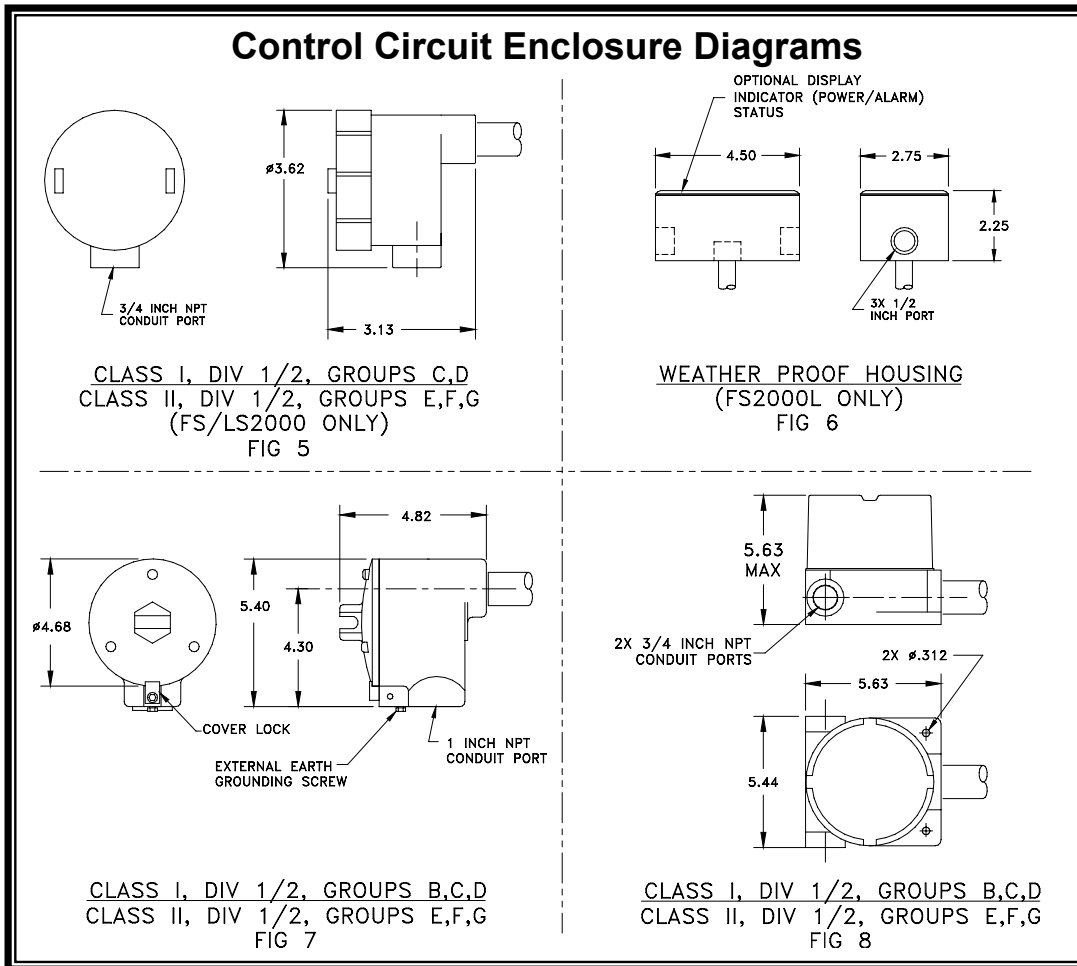

Section C - Instrument Wiring

There are three basic wiring configurations with the main difference being the way the instrument is powered. *Only qualified personnel are to wire or test this instrument. The operator assumes all responsibilities for safe practices while wiring or troubleshooting.* One of the following wiring instruction and diagrams illustrate the requirements for power input, alarm outputs and safety instructions for the unit being installed.

ALERT: *The Instrument contains electrostatic discharge (ESD) sensitive devices. Use standard ESD precautions when handling the instrument.*

Recommended Minimum Wire Gauge

The following wire gauge chart specifies the correct wire for the distance to the power source or loads. Note that the open collector option is limited to 50 ft. It is also recommended that the open collector cable is shielded and that it is not run in the same conduit with the power source or the relay load.

Connection	Maximum Distance for Wire Gauge					
	10 ft. (3M)	50 ft. (15M)	100 ft. (30M)	250 ft. (76M)	500 ft. (152M)	1000 ft. (305M)
Input Power 100 – 240Vac	22	20	18	16	14	12
Input Power 24(AC or DC)	24	24	22	22	20	18
Loop Power	24	24	22	22	20	18
Relay Output	18	16	14	12	10	x
Open Collector Output	24	22	x	x	x	x

Grounding

The switch must be properly ground for safety and operational reasons.

100 –240 Vac input power units: A minimum gauge of 14AWG is required on the earth ground terminal.  This connection should have a resistance to earth ground less than 1 ohm. Do not connect the earth ground to DC ground (terminals marked “GND” or “COM” or “-”).

24 volt and Two wire (loop powered) units: The earth ground wire will be attached to the inside of the enclosure on a grounding screw along with the ground wire from the control circuit. Use the recommended wire gauge specified for the input power and distance listed in the chart above. Do not connect the earth ground to DC ground (terminals marked “GND”, “COM” or “-“).

Input Power, 100-240 Vac

1. FCI recommends installing an input power disconnect and a fuse near the instrument to interrupt power during installation, maintenance, calibration, alarm selection and troubleshooting procedures. Conduit should also be installed according to the local electrical codes or hazardous location requirements. If the wires are to be pulled through the enclosure it is recommended that the control circuits be removed from the housing.
2. Ensure the power is off to the instrument before wiring the instrument.
3. With the enclosure cover removed, locate the 4-40 hold down screw next to the serial number block on the top control circuit (see Figure 12). Loosen the screw to release the edge of the top control circuit and flip up the top circuit to expose the bottom circuit.

Note: The 4-40 screw is captive on the control circuit.

4. If the control circuit requires removal, disconnect the sensor element wires from TB3 using a 3/32” flat head screwdriver. Remove the two Phillips screws on the bottom control circuit and pull the control circuit assembly out of the enclosure enough to expose the ground wire. Disconnect the ground wire and remove the control circuit assembly from the enclosure. After pulling wire to the enclosure, reassemble the control circuit assembly back into the enclosure before wiring the power and output. Make sure the green ground wire is reconnected to the enclosure.
5. Attach the ac power leads to TB4 as indicated on the control circuit. Make sure that an earth ground wire is attached to the earth ground terminal. See figure 9.
6. Attach the relay load wires to TB5. The relay contact conditions are shown in the alarm state (de-energized). The relay’s maximum rating is 6 amps 28Vdc-100/240Vac, resistive loads. The minimum current and voltage rating 20mA, 10 volts. If the load is less than the minimum values use the open collector terminal on TB1, top control circuit.
7. After making the connections to TB4 and TB5 (TB1), secure all the wires to the tie down bracket with a cable tie wrap. See figure 9. This is required by safety agencies to act as a strain relief and to prevent fly off of a wire with high voltage potential.
8. After making all the wire connections, flip down the top control circuit and secure it with the 4-40 captive screw.
9. Refer to the next section for functional verification and adjustments.

Input Power, 24 Vdc / Vac

1. FCI recommends installing an input power disconnect and a fuse near the instrument to interrupt power during installation, maintenance, calibration, alarm selection and troubleshooting procedures. Conduit should also be installed according to the local electrical codes or hazardous location requirements. If the wires are to be pulled through the enclosure it is recommended that the electronics be removed from the housing.
2. With the enclosure cover removed, locate the 4-40 hold down screw next to the serial number block on the top control circuit (see Figure 12). Loosen the screw to release the edge of the top control circuit and flip up the top control circuit to expose the terminal blocks on the bottom side.

Note: The 4-40 screw is captive on the control circuit.

3. If the control circuit requires removal, remove the green ground wire going to the ground screw. Disconnect the sensor element wires from TB3 using a 3/32” flat head screwdriver. Position the control circuit at a 45° angle to the plastic standoffs and snap the control circuit off the standoffs. Reinstall the control circuit before connecting the power and loads. To reassemble, snap the control circuit on the plastic standoffs at a 45° angle to the plastic standoffs and reconnect the element wiring.
4. Determine the type of power to be used (24Vac or 24Vdc) and attach the power leads to TB1 as indicated on the control circuit. See Figure 10. Make sure that an earth ground wire is attached to the earth ground terminal inside the housing.
5. Attach the relay load wires to TB2. The relay contact conditions are shown in the alarm state (de-energized). The relay’s maximum rating is 6 amps 28Vdc-100/240 Vac, resistive loads. The minimum current and voltage rating 20 mA, 10 volts. If the load is less than these values use the open collector terminal on TB1 See Figure 10.
6. After making all the wire connections, flip down the top control circuit and secure it with the 4-40 captive screw.
7. Refer to the next section for the set point and alarm state settings.

Input Power, Two Wire (Loop Power)

1. FCI recommends installing an input power disconnect and a 1/8 amp, fast blow fuse near the instrument to interrupt power during installation, maintenance, calibration, alarm selection and troubleshooting procedures. Conduit should also be installed according to the local electrical codes or hazardous location requirements. If the wires are to be pulled through the enclosure it is recommended that the electronics be removed from the housing.
2. With the enclosure cover removed, slide the control circuit out half way to expose terminal block P1, Figure 13.
3. If the control circuit requires removal, slide out the control circuit and remove the green ground wire going to the ground screw. Disconnect the sensor element wires from the Ref and Act. Reinstall the control circuit before connecting the power and loads.
4. Connect the loop power leads to P1 as indicated on the control circuit. See Figure 11. Make sure that an earth ground wire is attached to the earth ground terminal inside the housing. It is very important that the current loop connected to P1 maintains a voltage rang between 18 and 29.5 volts at the control circuit. Figure 11 shows a typical wiring configuration with a current sense device having 250Ω impedance. With this load, the power supply can be 22 to 33Vdc. Check the load impedance of the current sense device and the power supply and see if they are compatible the NuTec instrument.
5. If the open collector switch is needed, make the connections to P1. See example circuit Figure 11.
6. After making all the wire connections, slide the control circuit into the housing until it passes the rim of the housing.
7. Refer to the next section for the set point and alarm state settings.

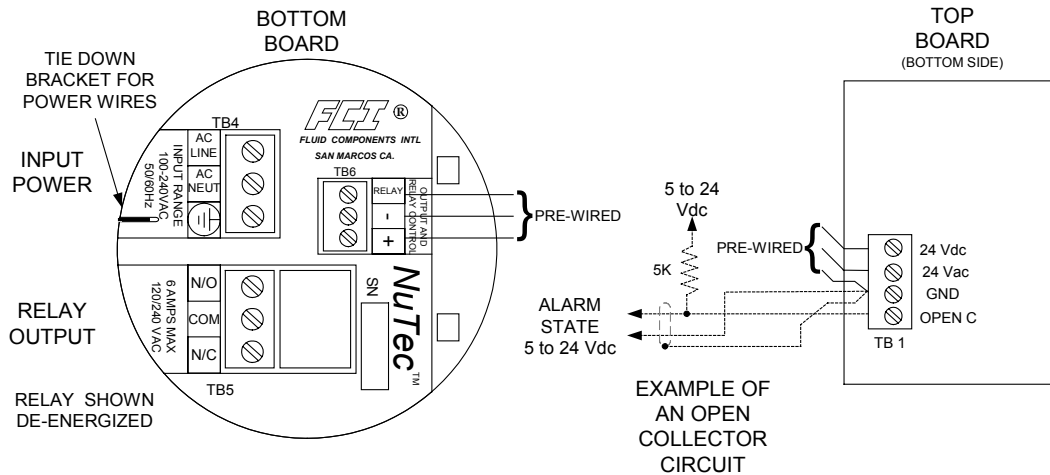

FIGURE 9 100 - 240 Vac Input Power

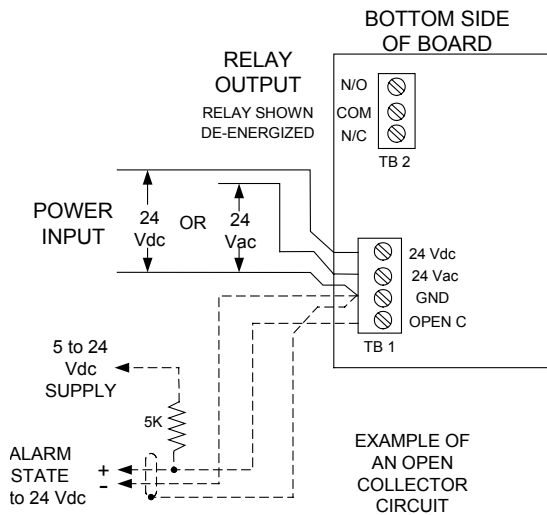

FIGURE 10 24 Vdc / Vac Input Power

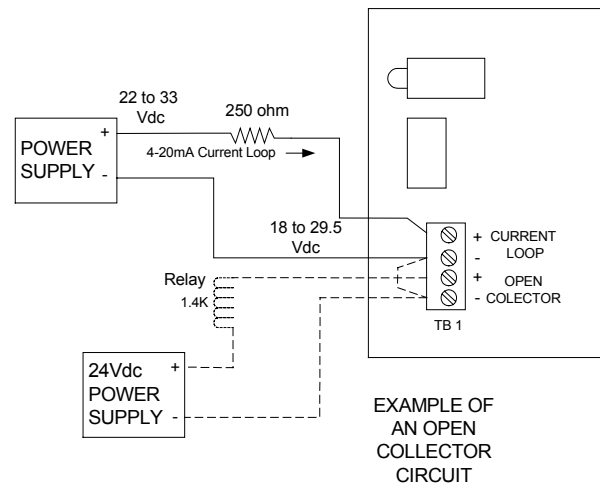

FIGURE 11 2 Wire (Loop Power)

Section D - Power Up, Functional Verification and Adjustment

Before Applying power to the instrument, it is recommended that a third party inspect the installation workmanship. Make sure wires are not pinched or frayed. Check for matching serial numbers on the sensing element and the control circuit. Verify that the power and alarm circuits are properly connected. Review the instrument configuration and its application.

On instruments powered by 100 –240Vac or 24Vdc/Vac, the power indicator is a green rectangular LED and the alarm indicator is a red rectangular LED. On instruments powered with two wires (loop power), power is indicated by either one of the red LEDs at the edge of the control circuit. The bottom LED (closest to control circuit) is the flow/wet indicator and the top LED is the no-flow/dry indicator.

Apply power and look for the power indicator light. After power is established let the instrument warm up for 5 minutes. Run the process at normal and then at abnormal conditions. In most cases the instrument will detect a flow or level alarm with the factory settings. If the Instrument does not respond, responds slowly or the alarm responds opposite to the required indication, proceed to the section pertaining to the type of control circuit provided. Refer to Figure 12 and 13 to familiarize yourself with the location of the adjustment potentiometers and jumpers.

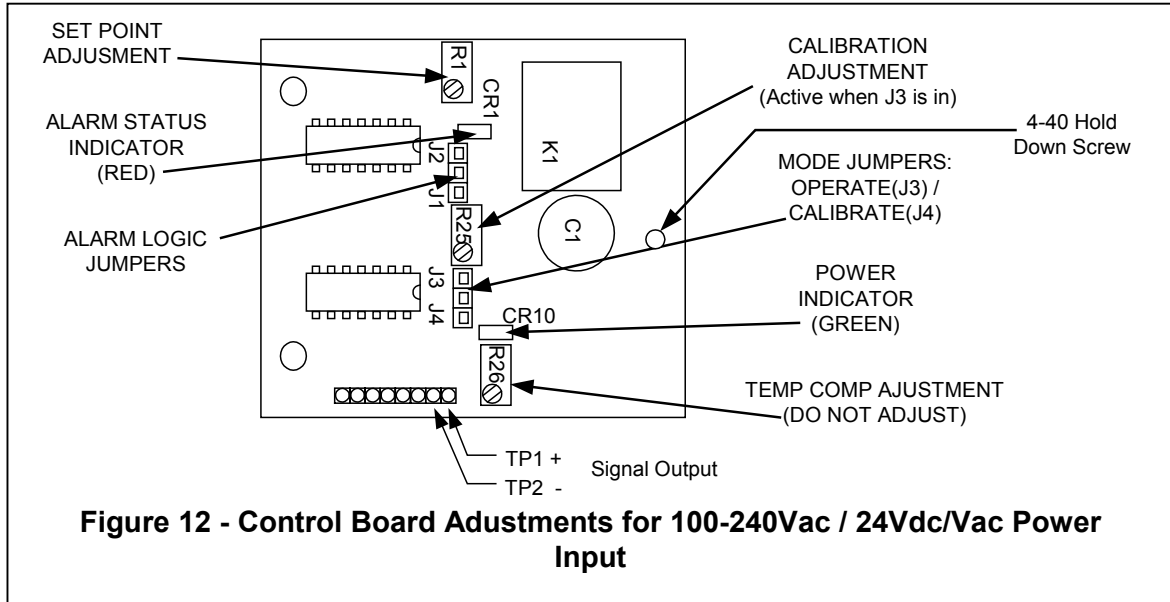

Adjustment by Observation - Input Power, 100-240Vac 24Vdc/Vac

The following instructions are for both flow and [wet/dry] applications. **NOTE: Do not adjust R26 located between the green LED and the edge of the control circuit.**

Detecting Decreasing Flow or [Dry] (Low Flow/[Dry] Alarm, jumper at J2)

Run the process at normal flow [raise the level]. If the alarm status LED is off, turn the set point adjustment potentiometer (pot) R1 clockwise until LED turns on. With the LED on, slowly turn the pot counterclockwise until the LED just turns off. Adjust the pot one-quarter turn counterclockwise past the point where LED turns off. Stop the process flow [lower level]. And verify that instrument has switched to the alarm state.

Detecting Increasing Flow or [Wet] (High Flow/[Wet] Alarm, jumper at J1)

Run the process at normal flow [lower the level]. If the alarm status LED is off, turn the set point adjustment potentiometer (pot) R1 clockwise until LED turns on. With the LED on, slowly turn the pot counterclockwise until the LED just turns off. Adjust the pot one-quarter turn counterclockwise past the point where LED turns off. Increase the process flow [raise level]. And verify that instrument has switched to the alarm state.

Adjustment by Measurement - Input Power, 100-240Vac 24Vdc/Vac

The following instructions are for both flow and [wet/dry] applications. Verify that the mode jumper is in the operation position (J3). Attach a DVM to TP1(+) and TP2(-). Establish a normal flow [wet or dry] condition, letting the instrument stabilize. Record the TP1 to TP2 voltage. Go to one of the following procedures as applicable. **NOTE: Do not adjust R26 located between the green LED and the edge of the control circuit.**

Detecting Decreasing Flow or [Dry] (Low Flow/[Dry] Alarm, jumper at J2)

Stop the process flow [lower level] allowing the instrument to stabilize. Record the TP1 to TP2 voltage. Average the normal and the abnormal process condition voltages (i.e., if the normal reading is 7 volts and the abnormal reading is 8 volts, the average or set point is 7.5 volts). The calculated set point must be at least 0.04 volts over the normal condition. Change the mode jumper to the Calibrate (Cal) position, (J4). Adjust the cal pot (R25) until the DVM equals the calculated set point voltage. If the Red LED is off, turn the set point pot slowly counterclockwise until the LED turns on. If the LED is on, turn the pot (R1) clockwise until the LED

turns off, then slowly turn the pot counterclockwise until the LED just turn on. Set the calibration jumper to the operate position (J3).

Detecting Increasing Flow or [Wet] (High Flow/[Wet] Alarm, jumper at J1)

Start an excessive process flow [raise level] allowing the instrument to stabilize. Record the TP1 to TP2 voltage. Average the normal and the abnormal process condition voltages (i.e., if the normal reading is 7 volts and the abnormal reading is 6 volts, the average or set point is 6.5 volts). The calculated set point must be at least 0.04 volts below the normal condition. Change the mode jumper to the Calibrate (Cal) position, (J4). Adjust the cal pot (R25) until the DVM equals the calculated set point voltage. If the Red LED is on, turn the set point pot slowly counterclockwise until the LED turns off. If the LED is off, turn the pot (R1) clockwise until the LED turns on, then slowly turn the pot counterclockwise until the LED just turn off. Set the calibration jumper to the operate position (J3).

Adjustment by Observation - Input Power, Two Wire (Loop Power)

The following instructions are for both flow and [wet/dry] applications. **NOTE: Do not adjust R32A and R35A located in the middle of the control circuit.**

Detecting Flow or [Wet (high level alarm)]

Set J1 to the "Wet/Flow" position. With the sensing element at no-flow or [dry], turn the set point potentiometer (pot) to the point where the LEDs toggle back and forth (clockwise to turn on the top LED, CR3, and counterclockwise to turn on the bottom LED, CR2). Turn the pot one turn clockwise past the point where the top LED (CR3) turns on. Turn on the flow [raise liquid level] and verify that the instrument switches to the alarm state when flowing or [wet].

Detecting No-Flow or [Dry (low level alarm)]

Set J1 to the "Dry/No-Flow" position. With the sensing element at flow or [wet], turn the set point potentiometer (pot) to the point where the LEDs toggle back and forth (clockwise to turn on the top LED, CR3, and counterclockwise to turn on the bottom LED, CR2). Turn the pot one turn counterclockwise past the point where the bottom LED (CR2) turns on. Stop the flow [lower liquid level] and verify that the instrument switches to the alarm state when not flowing or [dry].

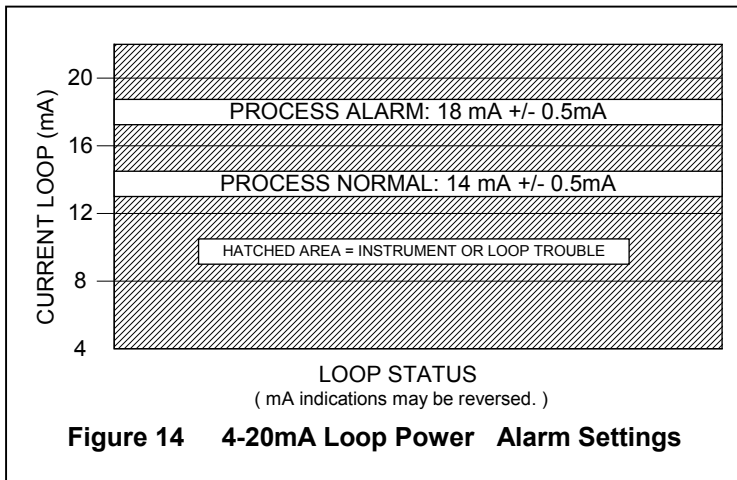
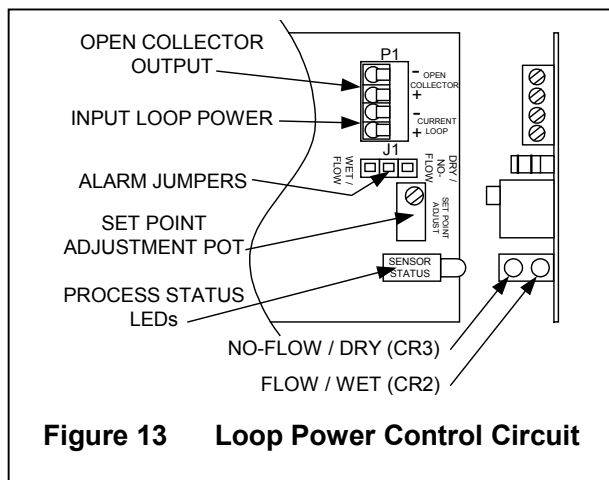

Section E - Maintenance and Troubleshooting

Maintenance: Typically required for the sensing element. If the process media sticks to the process pipes (or tank) the sensing element should be cleaned in the same manner and frequency as the process pipe (or tank). Occasionally check for moisture in the control circuit housing and wiring connections. Check for proper functionality and response time.

Troubleshooting: If the instrument is not operating, go through the installation and adjustment procedures and verify proper installation. If the instrument fails after some time in service and it has been checked, or if it fails to operate at start up and the installation has been verified, contact FCI Technical Service. If the instrument is to be returned, obtain a Return Authorization. The form contains a declaration of decontamination cleaning information that the instrument must comply with before it is shipped to FCI. The telephone number is 1-800-854-1993 or 1-760-744-6950.

NOTICE OF PROPRIETARY RIGHTS

This document contains confidential technical data, including trade secrets and propriety information that is the property of Fluid Components Intl (FCI). Disclosure of this data to you is expressly conditional upon your assent that its use is limited to use within your company only (and does not include manufacture or processing uses). Any other use is strictly prohibited without prior written consent of FCI.